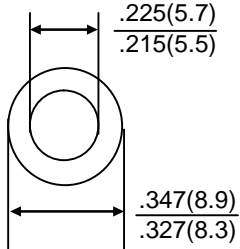
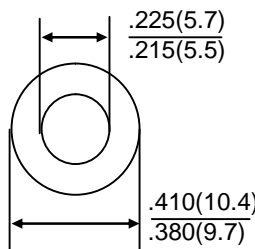
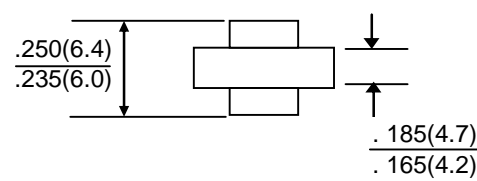

HIGH CURRENT AUTOMOBILE RECTIFIER	REVERSE VOLTAGE - 50 to 1000Volts FORWARD CURRENT - 25 Amperes
<p>FEATURES</p> <ul style="list-style-type: none"> ● Utilizing viod-free molded plastic technique ● Low power loss ● High Surge Capability ● High temperature soldering guaranteed: 265°C/10S <p>MECHANICAL DATA</p> <ul style="list-style-type: none"> ● Terminal: Plated axial terminals solderable per MIL STD-202E, Method 208C ● Case: Molded with UL-94 Class V-O recognized flame retardant epoxy ● Polarity: Color ring denotes cathode 	<div style="display: flex; justify-content: space-around;"> <div style="text-align: center;"> <p>ARS</p>  </div> <div style="text-align: center;"> <p>AR</p>  </div> </div> <div style="text-align: center; margin-top: 20px;">  </div> <p style="text-align: center;">Dimensions in inches and (millimeters)</p>

MAXIMUM RATINGS AND ELECTRICAL CHARACTERISTICS

Rating at 25°C ambient temperature unless otherwise specified.
 Single phase, half wave ,60Hz, resistive or inductive load.
 For capacitive load, derate current by 20%

CHARACTERISTICS	SYMBOL	ARS25A	ARS25B	ARS25D	ARS25G	ARS25J	ARS25K	ARS25M	UNIT
		AR25A	AR25B	AR25D	AR25G	AR25J	AR25K	AR25M	
Maximum Recurrent Peak Reverse Voltage	V _{RRM}	50	100	200	400	600	800	1000	V
Maximum RMS Voltage	V _{RMS}	35	70	140	280	420	560	700	V
Maximum DC Blocking Voltage	V _{DC}	50	100	200	400	600	800	1000	V
Maximum Average Forward Rectified Current @T _A =55 °C	I(AV)	25							A
Peak Forward Surge Current 8.3ms Single Half Sine-Wave Super Imposed on Rated Load	I _{FSM}	400							A
Maximum Instantaneous Forward Voltage (at Rated Forward Current)	V _F	1.1							V
Maximum DC Reverse Current @T _A =25°C at Rated DC Bolcking Voltage @T _A =150°C	I _R	10 1000							uA
Typical Junction Capacitance Element (Note1)	C _J	300							pF
Typical Thermal Resistance (Note2)	R _{θJA}	1.0							°C/W
Operating Temperature Range	T _J	-55 to +150							°C
Storage Temperature Range	T _{STG}	-55 to +150							°C
Polarity and Voltage Denotation Color Ring		Red	Yellow	Silver	Orange	Green	Blue	Violet	

NOTES:1.Measured at 1.0 MHz and applied reverse voltage of 4.0V DC.
 2.Thermal resistance from junction of ambient.

FIG. 1 – FORWARD CURRENT DERATING CURVE

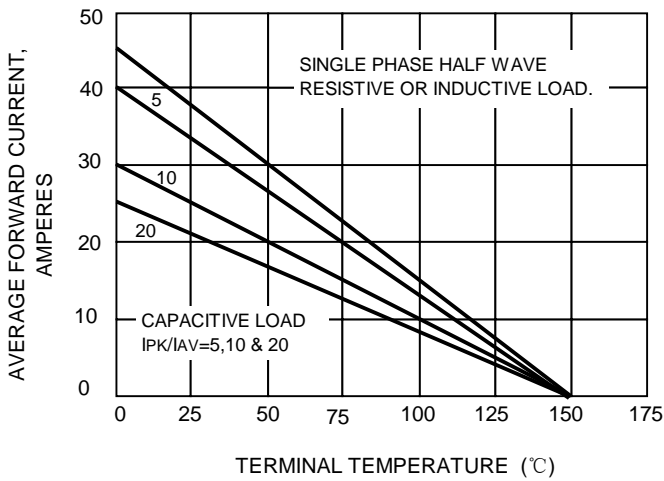

FIG.2-MAXIMUM NON-REPETITIVE
PEAK FORWARD SURGE CURRENT

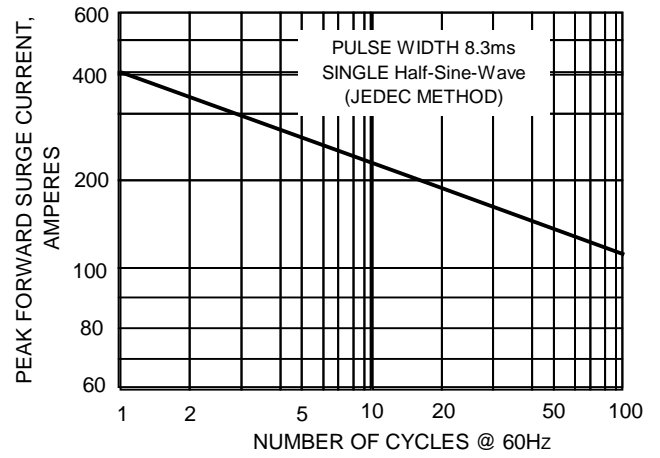

FIG.3-TYPICAL INSTANTANEOUS
FORWARD CHARACTERISTICS

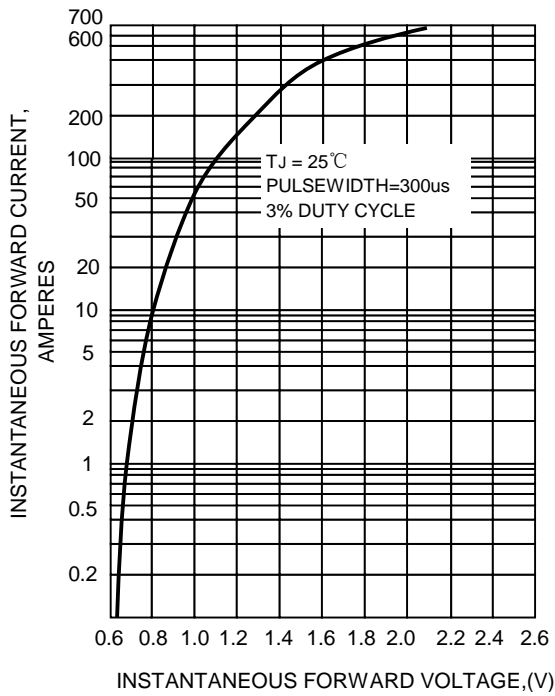

FIG.4-TYPICAL REVERSE
CHARACTERISTICS

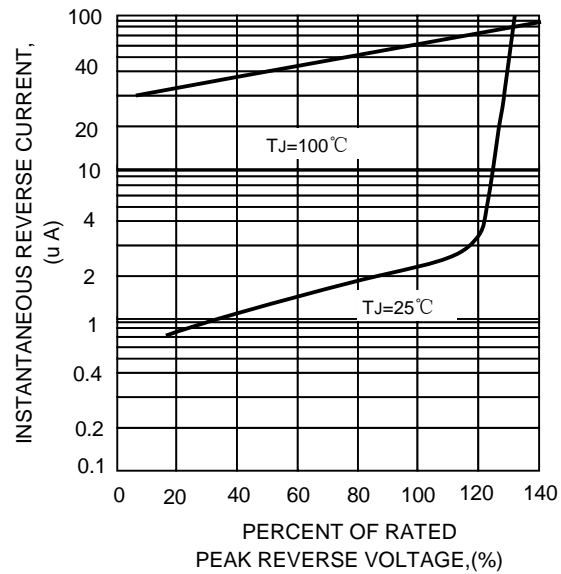

FIG.5-TYPICAL JUNCTION CAPACITANCE

