

SILICON BRIDGE RECTIFIERS

REVERSE VOLTAGE - 50 to 1000Volts
FORWARD CURRENT - 2.0 Amperes

FEATURES

- Surge overload rating -50 amperes peak
- Ideal for printed circuit board
- Reliable low cost construction utilizing molded plastic technique results in expensive product
- Mounting position :Any

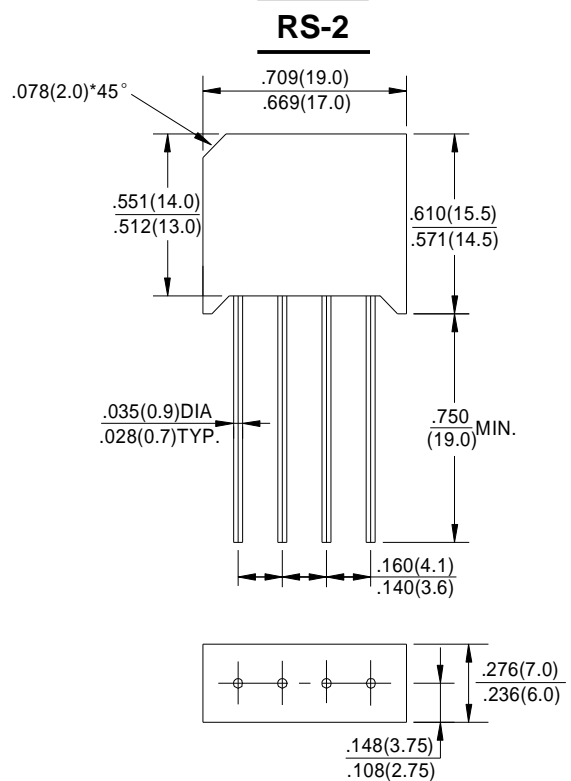

MAXIMUM RATINGS AND ELECTRICAL CHARACTERISTICS

Rating at 25°C ambient temperature unless otherwise specified.

Single phase, half wave ,60Hz, resistive or inductive load.

For capacitive load, derate current by 20%

| CHARACTERISTICS | SYMBOL | RS201 | RS202 | RS203 | RS204 | RS205 | RS206 | RS207 | UNIT |
|---|------------------|-------------|-------|-------|-------|-------|-------|-------|------------------|
| Maximum Recurrent Peak Reverse Voltage | V _{RRM} | 50 | 100 | 200 | 400 | 600 | 800 | 1000 | V |
| Maximum RMS Voltage | V _{RMS} | 35 | 70 | 140 | 280 | 420 | 560 | 700 | V |
| Maximum DC Blocking Voltage | V _{DC} | 50 | 100 | 200 | 400 | 600 | 800 | 1000 | V |
| Maximum Average Forward Rectified Current 0.375" (9.5mm) Lead Lengths @ T _A =40 °C | I(AV) | 2.0 | | | | | | | A |
| Peak Forward Surge Current , 8.3ms Single Half Sine-Wave Super Imposed on Rated Load (JEDEC Method) | I _{FSM} | 50 | | | | | | | A |
| I ² t Rating for Fusing (t<8.3ms) | I ² t | 15.0 | | | | | | | A ² s |
| Maximum Forward Voltage Drop Per Element at 2.0A Peak | V _F | 1.1 | | | | | | | V |
| Maximum DC Reverse Current at Rated DC Blocking Voltage T _J =25°C | I _R | 10.0 | | | | | | | µA |
| | | 1.0 | | | | | | | mA |
| Typical Junction Capacitance Per Element (Note1) | C _J | 30 | | | | | | | pF |
| Operating Temperature Range | T _J | -55 to +150 | | | | | | | °C |
| Storage Temperature Range | T _{STG} | -55 to +150 | | | | | | | °C |

Note:1.Measured at 1.0MHz and applied reverse voltage of 4.0V DC.

FIG.1-DERATING CURVE FOR
OUTPUT RECTIFIED CURRENT

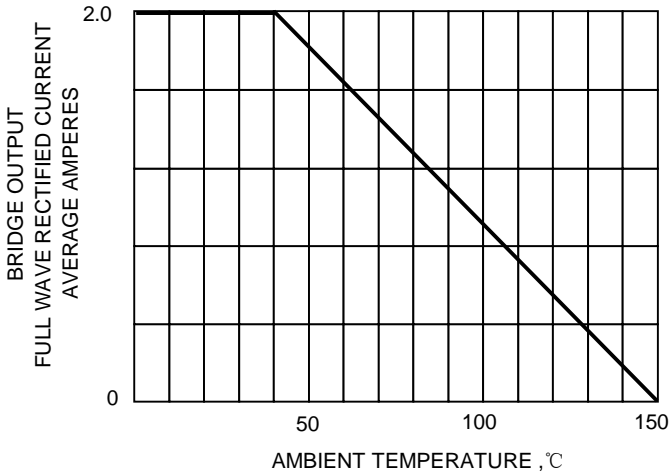

FIG.2-MXIMUM NON-REPETITIVE
SURGE CURRENT

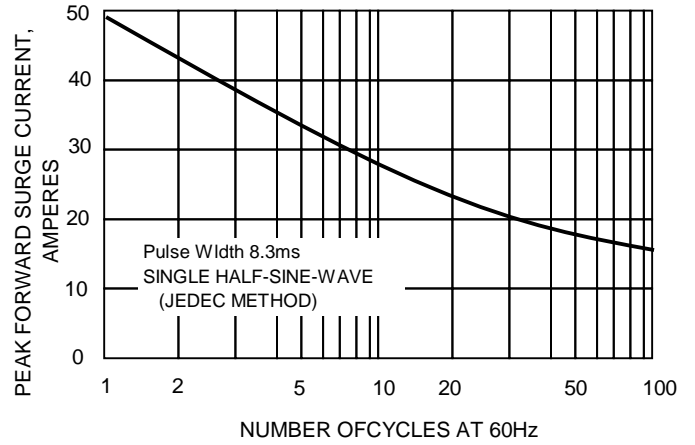

FIG.4-TYPICAL REVERSE
CHARACTERISTICS

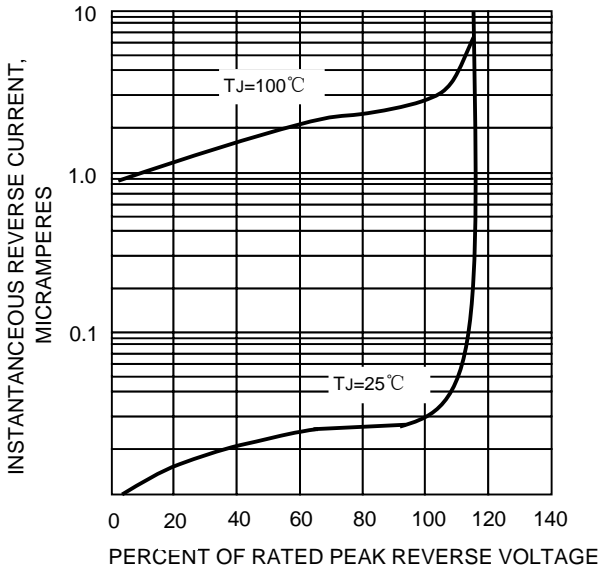

FIG.4-TYPICAL FORWARD CHARACTERISTICS

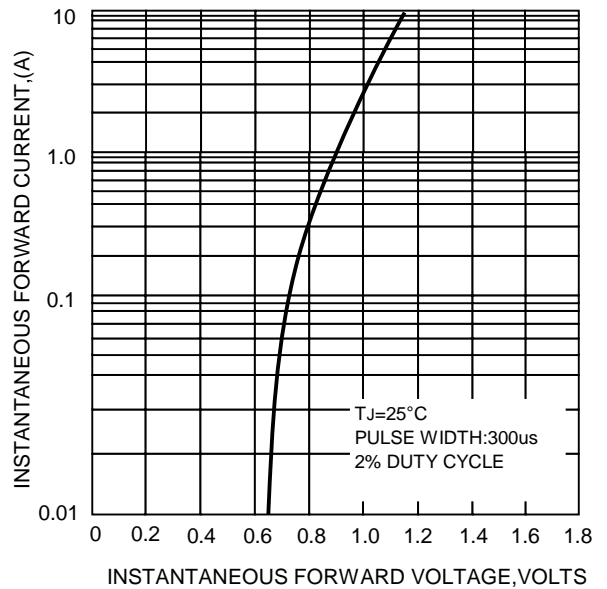

FIG.5-TYPICAL JUNCTION CAPACITANCE PER BRIDGE ELEMENT

